

Horizontal Reaction, P2 = 155 lbs  
Horizontal Reaction increased to 395 lbs  
w/ (1) #10 sds installed into return lip

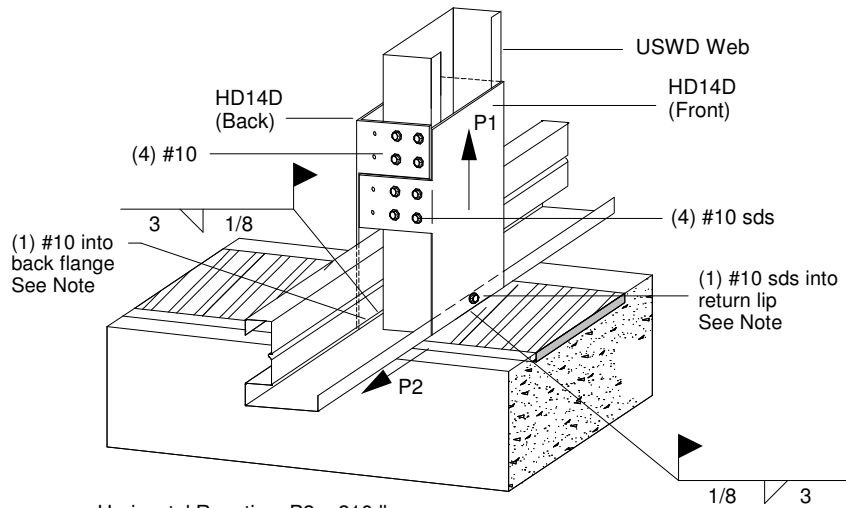
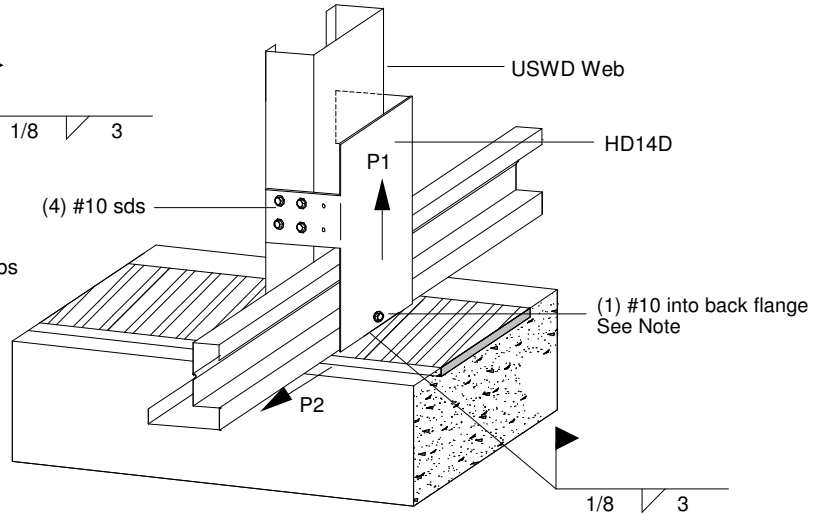

Horizontal Reaction, P2 = 310 lbs  
Horizontal Reaction increased to 795 lbs  
w/ (1) #10 sds installed into return lip and  
back flange

MAXIMUM CAPACITY (LBS)		
	WEB	UPLIFT P1
1224HD14D	035	1945
	046	3350
	057	3490
1226HD14D	035	1945
	046	3350
	057	3820

Values based on steel thickness of 1/4" - 1/2"

MAXIMUM CAPACITY (LBS)		
	WEB	UPLIFT P1
(2) 1224HD14D	035	3880
	046	6700
	057	6980
(2) 1226HD14D	035	3880
	046	6700
	057	7640

Values based on steel thickness of 1/4" - 1/2"

- 1) Min. screw spacing & edge distance = 9/16"
- 2) Min. bearing width = 3". Min steel thick = 0.150"
- 3) Welders and welding procedures shall be qualified as specified in AWS D1.3
- 4) Min. filler metal strength, Fxx = 70 ksi
- 5) When this connection detail is applied to both plies of a 2-ply truss, the capacities double
- 6) This detail does not indicate or imply that the depicted bearing is structurally adequate for the loads shown. Design of bearing is required
- 7) Max. Reactions shown are non-concurrent.



METAL FRAMING, a division of MITE®

www.AEGISMETALFRAMING.COM

14515 N. Outer 40 Drive Suite 110

Chesterfield, MO 63017

Phone:866/902-3447 Fax:314/434-5234

## USC TRUSS TO BEARING CONNECTION 1224/1226HD14D - EMBED PLATE

DETAIL NO.

# D-EMB-3

CATEGORY

STANDARD DETAILS

DATE

3/3/09